



Endoline's range of case formers offers an ideal first step to packaging automation. The machines are designed to reduce the time and effort taken to manually erect a case, at a low capital cost. The machines fold the lower flaps and hold the open case steady to allow packing to take place with both hands.

Features of the P1/2/3 - SF - H and P1/2/3 - SF - A include:

P1/2/3 - SF - H



Each machine can be used either on its own or close-coupled to a case sealer to provide a simple and effective system and is suitable for a range of case sizes; P1 allows for a small range, P2 medium range and P3 a large range for case forming, loading and sealing. The H denotes that these machines are fixed in the horizontal position, which is ideal for most applications.

P1/2/3 - SF - A



The A denotes that these machines can be set to an angled position, which is ideal for products that are unstable such as bags or bottles. The machine incorporates a section of horizontal belt drive so the case is horizontal at entry to the sealer.

Efficient



Our case formers reduce the time and effort taken to manually erect and load a case and you can also save space and time by eliminating the need to hold pre-erected cases near the packing area.

Compact

Width:
482mm
Length:
695mm

Our machines have a compact footprint and will not take up a great deal of space in your production area. They are fully portable with adjustable legs to enable the tilt angle to be customised.

Simple to operate



With no need to make any adjustments for size change, they can be set up and running in seconds.

Low cost of ownership



All Endoline's machines are designed for maximum efficiency and productivity thereby reducing the cost of ownership to a minimum. Our case formers come at a low capital cost and immediate savings can be seen through reduced labour costs and increased packing speeds.



P1/2/3-SF-H P1/2/3-SF-A Case Formers

Options include:

- Locating spacers to secure to a case sealer
- Locking castors

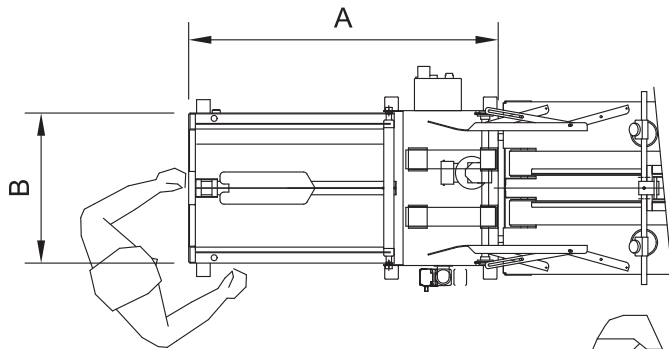

	A	B	C
P1 - SF - H	695	482	615-900
P2 - SF - H	790	662	625-925
P3 - SF - H	900	762	605-905

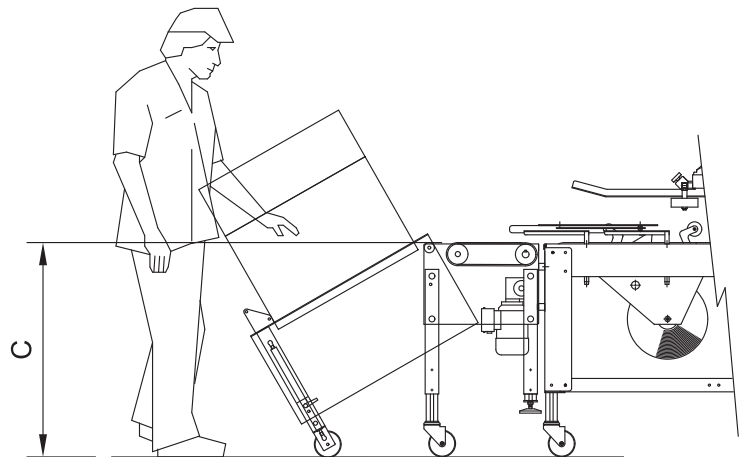

	A	B	C
P1 - SF - A	1155	382	700-980
P2 - SF - A	1155	560	700-980
P3 - SF - A	1155	660	700-980

Case Dimensions (mm)

	Length min/max	Width min/max
P1 - SF - H	200/400	120/250
P2 - SF - H	200/500	150/400
P3 - SF - H	200/600	150/500
P1 - SF - A	200/600	120/250
P2 - SF - A	200/600	150/400
P3 - SF - A	200/600	150/500

Pneumatics
5.5bar supply pressure

Machine Finish
Mild steel powder coated white
(RAL 9010) or stainless steel

© Endoline reserves the right to change specifications without prior notice.



Endoline Machinery Limited
Stratton Business Park, London Road
Biggleswade, Bedfordshire
SG18 8QB
United Kingdom

Telephone: +44 (0) 1767 316422
Facsimile: +44 (0) 1767 318033
E-mail: sales@endoline.co.uk
Website: www.endoline.co.uk

phoenix range