



This fully automatic case taper offers outstanding productivity on light cases typically used in the snack food industry. It takes open cases from a conveyor and seals top and bottom using self-adhesive tape.

Features of the 702 include:

High Speed System



Offers secure, accurate taping at up to 25 cases per minute, with no operator required.

Ease of Operation



The 702 is easy to install with height adjustment and castors. It has simple mechanical operation and clear access for easy cleaning and maintenance.

Four Column Construction



The use of our unique four column design provides added stability for the taping bridge to ensure the machine runs smoothly at all times with minimal interruption. This fully automatic machine is fitted with two pairs of columns for additional support to the folding section.

Robust Construction



High quality components housed in a robust chassis ensure minimal servicing and enable 24 hour operation. All our case tapers are designed for the rigours of typical end-of-line packaging environments.

Interchangeable Tape Heads



The 702 uses any machine tape up to 50mm wide, 1000m long and features instantly removable, interchangeable tapeheads, easily threaded, with integral knife guards.

Extended Warranty



Two year fully comprehensive warranty for peace of mind and reduced cost of ownership.



702

Pre-Set Fully Automatic Case Taper

Options include:

- Low tape and no tape sensing
- Visual/audible alarm
- Discharge blocked sensing
- Third top or bottom tapehead

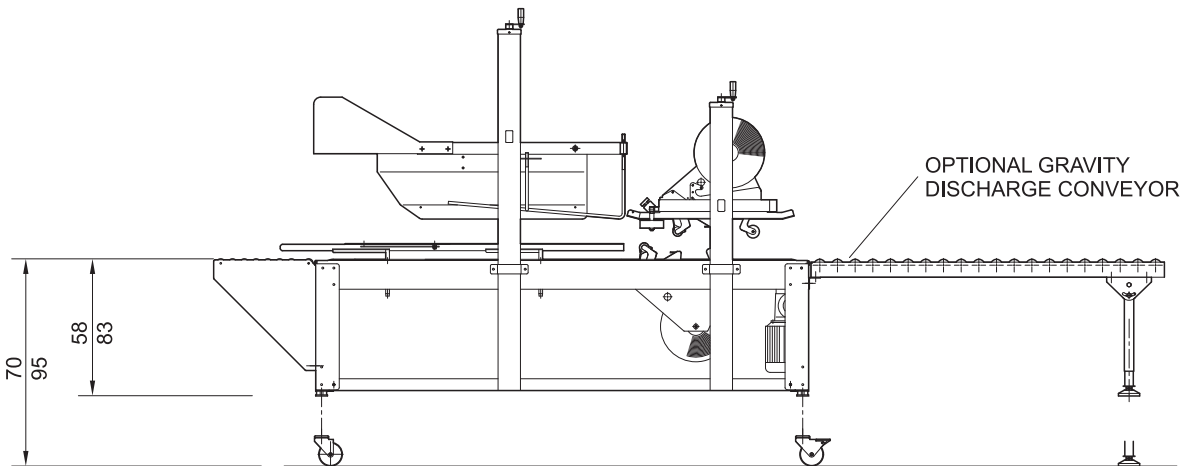
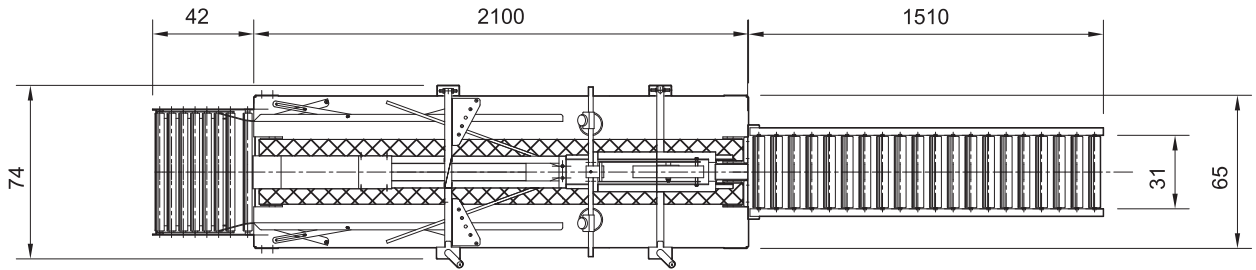

Endoline Machinery Limited
 Stratton Business Park, London Road
 Biggleswade, Bedfordshire
 SG18 8QB
 United Kingdom

Telephone: +44 (0) 1767 316422
 Facsimile: +44 (0) 1767 318033
 E-mail: sales@endoline.co.uk
 Website: www.endoline.co.uk

Case Dimensions (mm)

	Length	Width	Height
Minimum	150	130	110
Maximum	600	490	510

Electrical Supply

Single phase: 240V, 50Hz, 0.37kW
 Three phase: 415V, 50Hz, 0.37kW

Pneumatics

80psi (5.5 bar)

Machine Finish

Mild steel, powder coated white (RAL9010) or stainless steel

Tape Size

Standard: up to 50mm wide
 Optional: up to 75mm wide

© Endoline reserves the right to change specifications without prior notice.