



This hand fed case taper is suitable for short or long runs of the same case size and can seal cases from 50mm high with self-adhesive tape.

### Features of the 706 include:

#### Floating Bridge



This unique design feature allows the machine to accept swollen or out-of-specification cases while providing consistent and accurate sealing.

#### Twin Column Construction



Our unique twin column design provides added stability for the taping bridge to ensure the machine runs smoothly at all times with minimal interruption. It provides the support necessary for the floating bridge feature.

#### Interchangeable Tape Heads



The 706 uses any machine tape up to 50mm wide, 1000m long and features instantly removable, interchangeable tapeheads, easily threaded, with integral knife guards.

#### Ease of Operation



The 706 has simple mechanical operation and clear access for easy cleaning and maintenance. It also offers rapid adjustment for size changes therefore minimising down time.

#### Robust Construction



High quality components housed in a robust chassis ensure minimal servicing and enable 24 hour operation. All our case tapers are designed for the rigours of typical end-of-line packaging environments.

#### Extended Warranty



TWO YEAR fully comprehensive warranty for peace of mind and reduced cost of ownership.



# 706

## Semi-Automatic Pre-Set Case Taper

### Options include:

- Low tape sensing
- Low tape and no tape sensing
- Visual/audible alarm
- Discharge blocked sensing
- Packing tables
- Infeed/discharge conveyors
- Coding systems

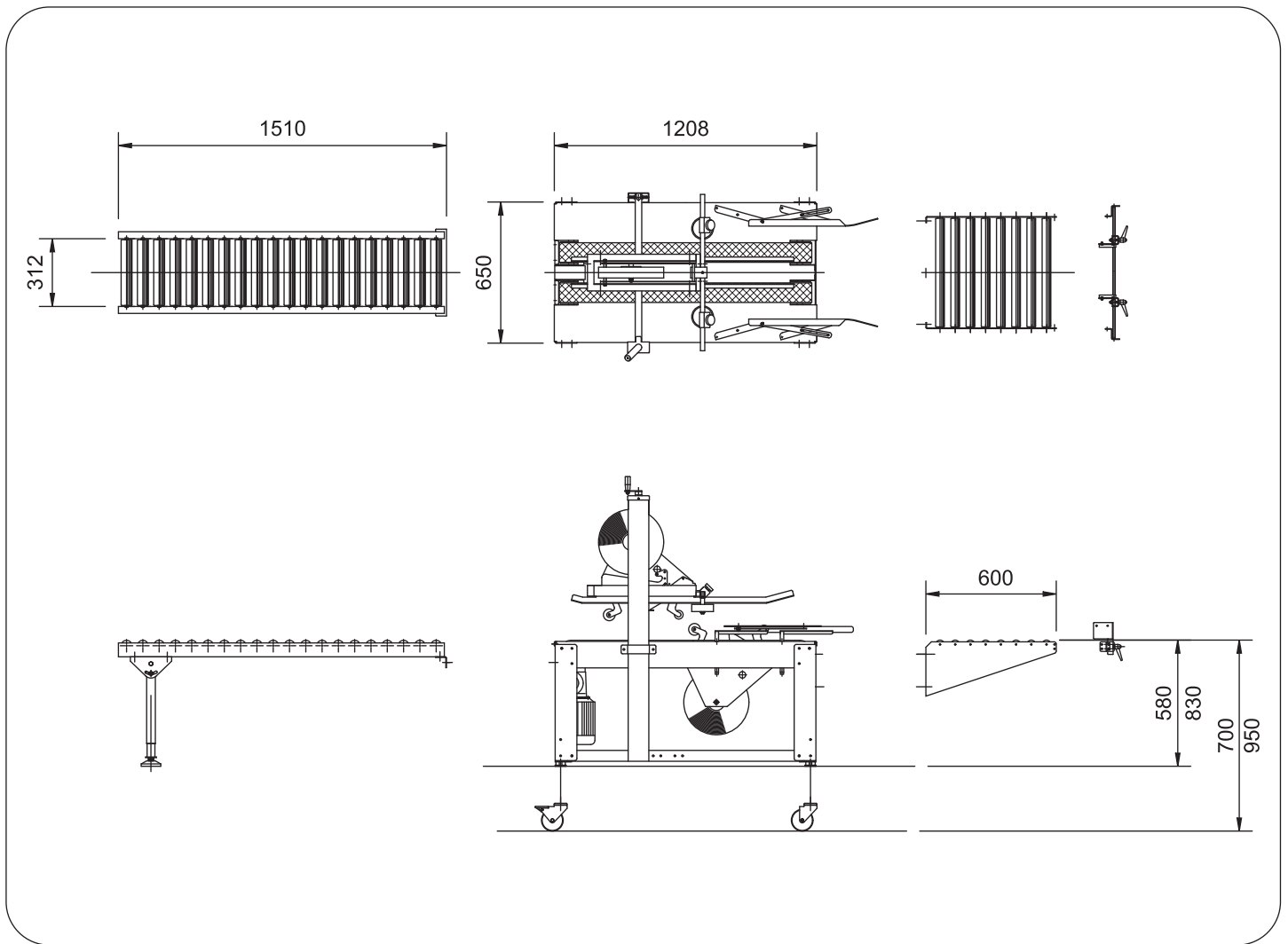

**Endoline Machinery Limited**  
Stratton Business Park, London Road  
Biggleswade, Bedfordshire  
SG18 8QB  
United Kingdom

Telephone: +44 (0) 1767 316422  
Facsimile: +44 (0) 1767 318033  
E-mail: sales@endoline.co.uk  
Website: www.endoline.co.uk

### Case Dimensions (mm)

	Length	Width	Height
Minimum	110	114	50
Maximum	inf	500	510

### Electrical Supply

Single phase:  
240V, 50Hz, 0.37kW

Three phase:  
415V, 50Hz, 0.37kW

### Machine Finish

Mild steel, powder coated white  
(RAL9010) or stainless steel

### Tape Size

Standard: up to 50mm wide  
Optional: up to 75mm wide

© Endoline reserves the right to change specifications without prior notice.