



(Flexi Conveyor shown is optional)

Suitable for single operator packing and sealing of cases that are consistent in size, this machine includes an infeed packing table, floating bridge, locking castors, interchangeable tapeheads and adjustable legs as standard.

Features of the P6-SP-T include:

Floating Bridge



The floating bridge allows the machine to accept swollen or out-of-specification cases while providing consistent and accurate sealing. A bridge-latch enables quick and easy access to the bottom tapehead for quick tape reload without re-adjustment.

Twin Column Construction



The use of our unique twin column design provides added stability for the taping bridge to ensure the machine runs smoothly at all times with minimal interruption and it provides the support necessary for the floating bridge feature.

Compact

Width:
908mm
Length:
1313mm

Our machines have a compact footprint and will not take up a great deal of space in your production area. They are fully portable with adjustable legs with height scales for easy installation.

Interchangeable Tapeheads



The instantly removable, interchangeable tapeheads are easily loaded and are fitted with integral steel knife guards. This means that fewer spare tapeheads are required thereby significantly reducing spare parts costs. Rapid tape reload (top and bottom) can be achieved just by swapping tapeheads.

Efficient



This machine is designed for quick and easy manual size change and a tool-free changeover for each case size and can be run by a single operator with automatic taping to improve case packing efficiency.

Low Cost of Ownership



All Endoline's machines are designed for maximum efficiency and productivity thereby reducing the cost of ownership to a minimum. This case sealer comes at a low capital cost and immediate savings can be seen through reduced labour costs and increased packing speeds.



P6-SP-T

Semi-Automatic Pre-Set Case Taper

Options include:

- Case clamps
- Discharge conveyor

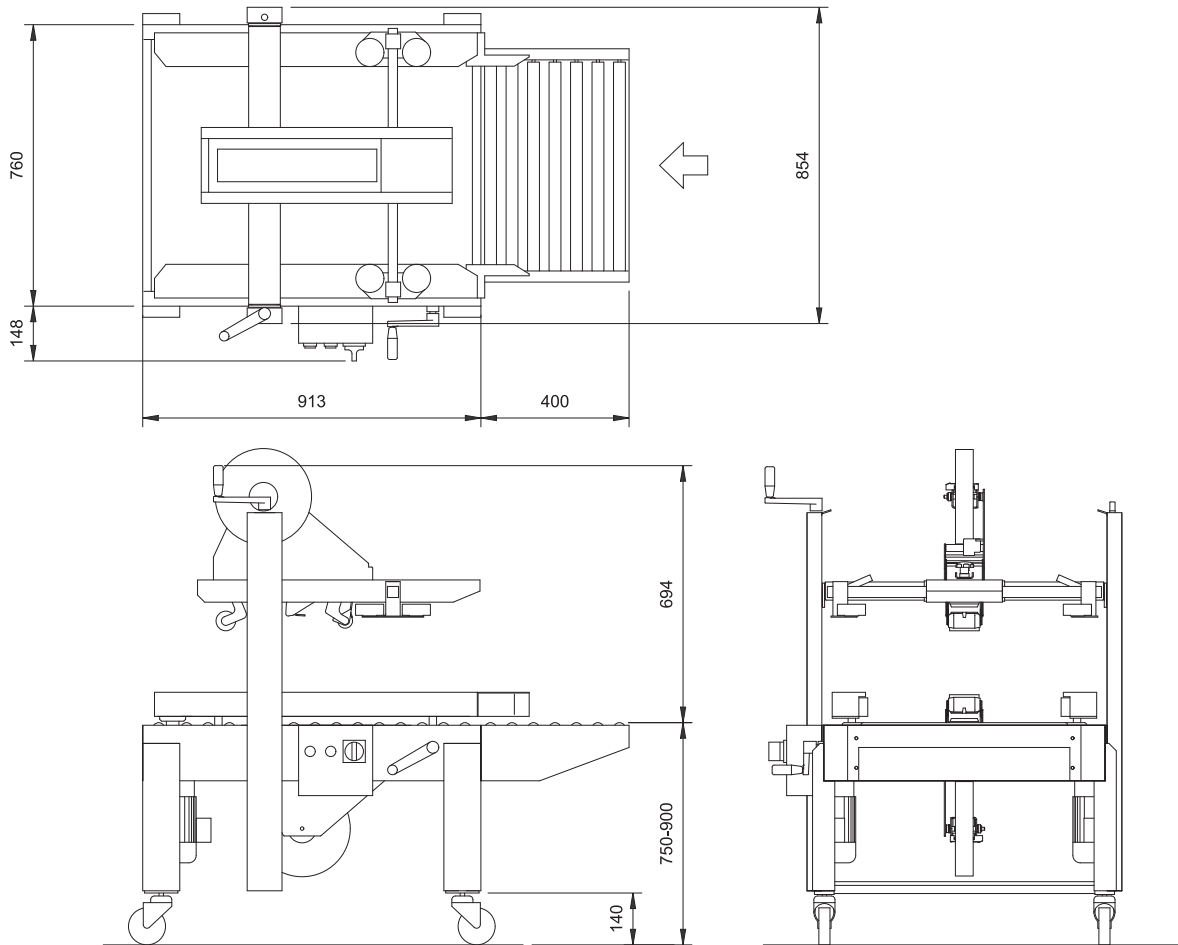

Case Dimensions (mm)

Length	Width	Height
120 to Inf	100 to 500	110 to 500

Electrical Supply

240V/1ph/50Hz
500W
2 amps nominal

Machine Finish

Mild steel painted RAL9010

Tape Size

Standard: up to 75mm wide

Bed Height

With castors 600 - 820mm

Handing

Right to left

Controls

Stop/Start and Remote
Emergency Stop

© Endoline reserves the right to change specifications without prior notice.



Endoline Machinery Limited
Stratton Business Park, London Road
Biggleswade, Bedfordshire
SG18 8QB
United Kingdom

Telephone: +44 (0) 1767 316422
Facsimile: +44 (0) 1767 318033
E-mail: sales@endoline.co.uk
Website: www.endoline.co.uk