

Versapack

Compact case erecting and packing system

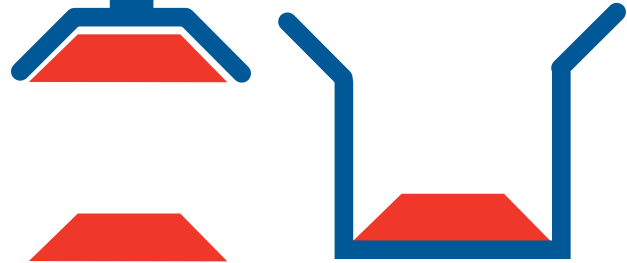

The Versapack™ is the smallest and fastest combined case erecting and packing machine on the market today and now has the unique ability to pack products in almost any orientation, including 'on-edge'.

Based on the highly successful Endoline 200 Series compact case erector and the Quin revolutionary Rtheta™ high speed picking head, the Versapack™ provides outstanding performance in the automation of end of line packaging.

- Ideal for shelf ready display with unique ability to pack products flat or 'on-edge'.
- Compact footprint of approximately 2m x 2m.
- High speed pick and place, typically 70 cycles per minute with 2kg load.
- Flexibility to provide packing formats with multiple rows, columns or layers.
- Case can be sealed with glue or tape.
- Bespoke picking heads to handle cartons, sealed trays, flow-wrap packs, flexible packs and roll-wraps.

Packing formats:

The Versapack™ is suitable for a wide range of packaging formats including regular slotted cases (RSC) and shelf-ready packaging (SRP).

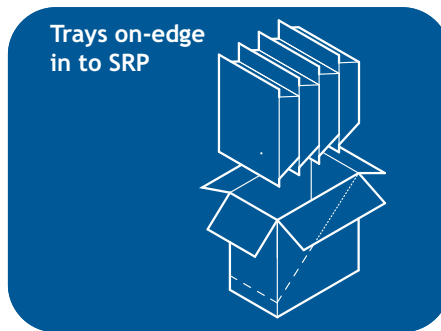
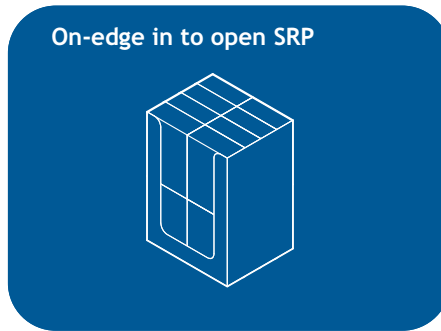
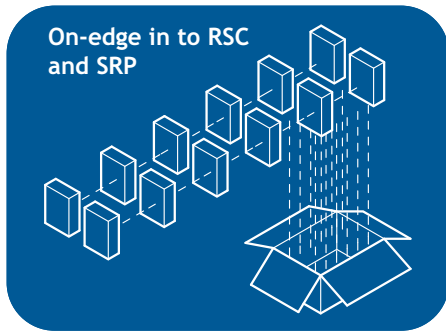

Plus many more...

Versapack



Typical layout

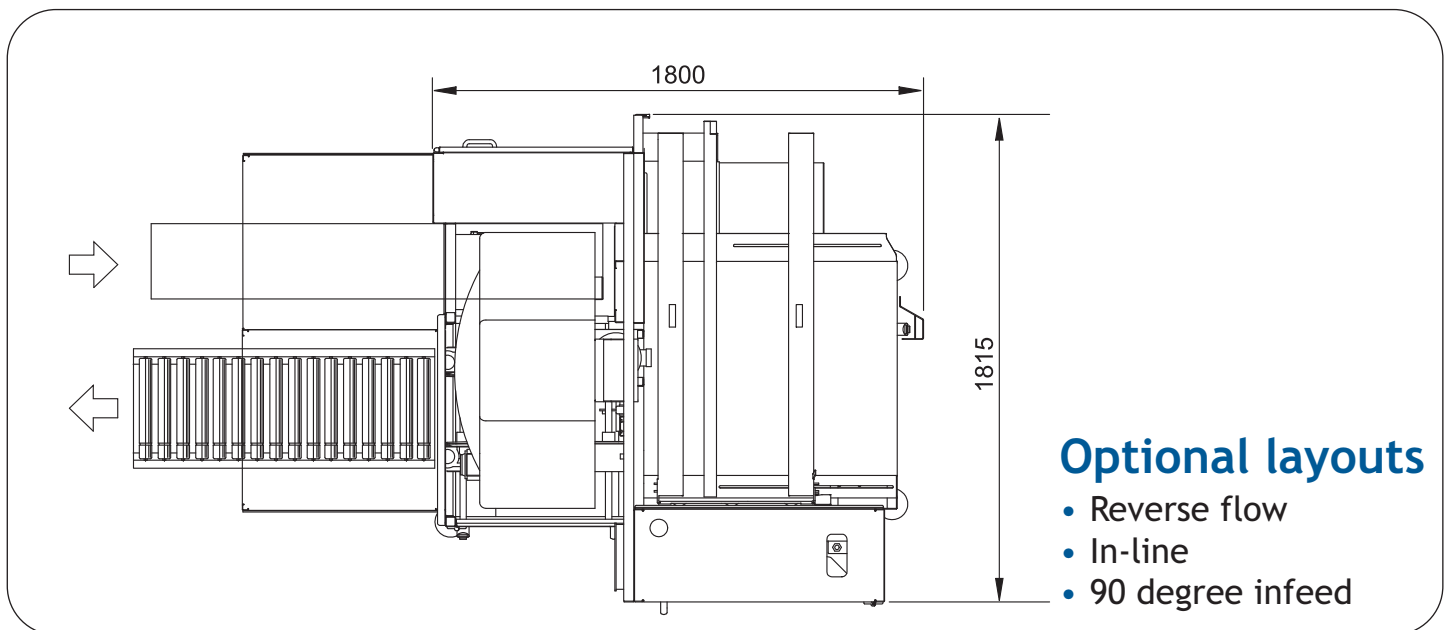

Contact us now to discuss your application

www.versapack.co.uk e-mail: info@versapack.co.uk



Telephone: +44 (0) 118 977 1077
Website: www.quin.co.uk



Telephone: +44 (0) 1767 316422
Website: www.endoline.co.uk